



Composite Water Heater

PART NUMBER
24E507009G03C

ABBREVIATED

Component Maintenance Manual with Illustrated Parts List

REV. NC, Dated 10/15/24

THE INFORMATION CONTAINED HEREIN IS THE PROPERTY OF LOOP AEROSPACE AND ANY DISCLOSURE OF THE CONTENTS TO OTHERS IS GIVEN IN CONFIDENCE. THIS MATERIAL MUST NOT BE REPRODUCED OR COPIED OR OTHERWISE DISCLOSED IN WHOLE OR IN PART WITHOUT THE SPECIFIC APPROVAL OF LOOP AEROSPACE, SANTA CLARITA CA 91350. COPYRIGHT 2023

LoopPMA.com
Loop Aerospace
Santa Clarita, CA 91350



Log of Revisions

Rev.	Date	Pages Affected	Approval
N/C	10/15/24	Initial Release	Bert Brache



TABLE OF CONTENTS

<u>Subject</u>	<u>Chapter Section</u>	<u>Page</u>
COVER PAGE		
RECORD OF REVISIONS		
TABLE OF CONTENTS		
INTRODUCTION		
DESCRIPTION AND OPERATION	1	1
TESTING AND FAULT ISOLATION	2	4
AUTOMATIC TEST REQUIREMENTS	3	11
DISASSEMBLY (Partial Only)	4	11
CLEANING	5	13
INSPECTION/CHECK	6	14
REPAIR	7	14
ASSEMBLY	8	15
SPECIAL TOOLS, FIXTURES, AND EQUIPMENT	9	19
ILLUSTRATED PARTS LIST	10	20



COMPONENT MAINTENANCE MANUAL
MODEL NUMBER: 24E507009G03C

INTRODUCTION

This abbreviated component maintenance manual complies with the intent of specification ATA 100. It is intended to provide the information necessary to perform minor shop maintenance and repair of part number 24E507009G03C Water Heater by repair stations, repairmen and or licensed technicians.

The 24E507009G03C Water Heater is manufactured by:

Loop Aerospace
21618 Golden Triangle Road, Suite 101
Santa Clarita, CA 91350
Phone 661-313-8050
Email Info@LoopAerospace.com

Sections which do not apply to the water heater are shown as "(NOT APPLICABLE)".

Weights and measures used in this abbreviated component maintenance manual are in English units, followed by metric equivalent in parentheses if required for better understanding.

WARNINGS, **CAUTIONS**, and **NOTES** are used throughout the text to highlight and emphasize important points as they become necessary. **WARNINGS** give information which must be followed precisely to avoid personal injury. **CAUTIONS** contain information which must be followed to avoid damage to equipment. **NOTES** assist the reader and provide additional information.

The following abbreviations have been used in this manual:

REF. Reference
AR. As Required



COMPONENT MAINTENANCE MANUAL
MODEL NUMBER: 24E507009G03C

THIS PAGE INTENTIONALLY LEFT BLANK

1. DESCRIPTION AND OPERATION

A. Description.

The water heater, p/n 24E507009G03C, shown in Figure 1 is typically located in the aircraft lavatory to provide warm water as part of the potable water system. The water heater tank is made of composite material and shrouded by an aluminum housing to thermally insulate the pressurized tank and provide high heat retention, while the exterior of the water heater remains cool to the touch. The stainless-steel water inlet fitting is located on the bottom of the tank, allows potable water to flow in a swirling action to mix with temperature controlled heated water as selected on the control printed circuit board and sensed by the thermistor temperature sensor.

The top cover is removable to access the circuit board to adjust the temperature of the water. The circuit board is preset at the factory to the MED setting of $110^{\circ}\text{F} \pm 10^{\circ}\text{F}$ (43.3°C). The user can easily decrease or increase the water temperature on the circuit board to select a different temperature. An overheat switch is located under the top cover of the tank which provides one of the safety features of the water heater. The bottom cover is also easily removable to access the cartridge heaters for maintenance or replacement along with the relief valve, another safety feature in case of water over-pressure.



PART NUMBER 24E507009G03C
WATER HEATER
FIGURE 1

B. Operation.

The water heater is powered by a 115VAC power source. This power is utilized by the circuit board depicted in Figure 2 in order to control the water heater. Current is directed through the overheat thermostat to the On/Off toggle switch and then flows out through the circuit board. If the water tank is filled, the circuit is completed via the water sensor establishing the required connection for the circuit board to proceed with temperature control. When the water temperature is lower than the temperature selected, power is transmitted from the circuit board relay to the heater elements. As soon as the water temperature reaches the temperature set point, the circuit board opens the relay to interrupt the power to the heater elements. In case the water temperature surpasses the specified maximum temperature, the overheat thermostat switch opens, breaking the circuit, and shutting off the power to the circuit board, shutting off the water heater elements. The overheat thermostat switch resets automatically when the water temperature drops below 100° F. In situations where the water tank is not filled, the water sensor switch opens, breaking the circuit and discontinuing the power supply to the water heater element.

The electrical schematic below is inside the top cover of the water heater. Also accessible under the top cover is the circuit board, electrical connections and temperature adjustment.

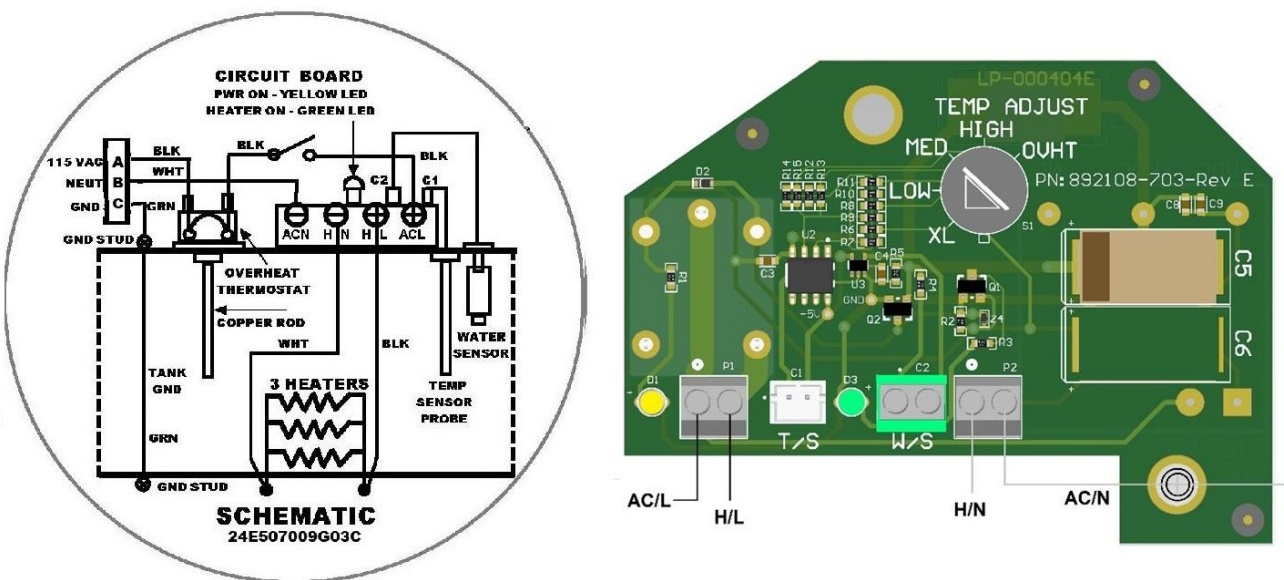

ELECTRICAL SCHEMATIC AND CIRCUIT BOARD CONNECTIONS

FIGURE 2

NOTE

AC/L – 115VAC, **AC/N** – NEUTRAL, **H/L** – HEATER LOAD, **H/N** – HEATER NEUTRAL, **T/S** – TEMPERATURE SENSOR, AND **W/S** – WATER SENSOR



C. Leading Particulars.

Leading particulars for the water heater are listed in Table 1.

NOTE: The factory presets the outlet water temperature to the MED setting on the circuit board, which is $110^{\circ} \pm 5^{\circ}$ F and within the specified range presented in Table 1. This preset temperature can be easily changed by the customer to a higher or lower setting as desired. It is important to note that a slight deviation from the customer's specified temperature may occur due to variations in test setup or if the water heater has been in service for a length of time.

Service Medium	Potable Water
Water Inlet Pressure	12 - 25 psi
Water Capacity	1.09 Quart (1.0L)
Outlet Water Temperature Range	90°-120° F (32.2° - 48.9° C)
Power Requirements	115VAC, 400/60Hz, 210W, Single Phase
Empty Weight	3.9 Pounds (1.77 Kg)
Height	12.9 Inches (328 mm)
Diameter	4.0 Inches (101 mm)

LEADING PARTICULARS
TABLE 1

2. TESTING AND FAULT ISOLATION

A. General

Testing shall be conducted at ambient temperature and ground level air pressure with electrical components thoroughly dry.

B. Examination

Prior to performing any testing, confirm that the water heater is in good mechanical condition. Refer to Inspection/Check. Perform testing and fault isolation only after thoroughly examining the water heater or any mechanical defects. Testing and fault isolation is performed to determine functional operation.

C. List of equipment

Refer to table 2 for a list of test equipment. Equivalent substitutes may be used. Basic hand tools required including small straight slot screwdriver for temperature selection on circuit board.

ITEM	IDENTIFICATION	SOURCE
Water Source and Regulator	20-30 psi	Local fabrication
Pressure gage	0-200 psi	Local purchase
Power Supply	115VAC, 400 or 60 Hz, min. 5 amps single phase	Local purchase
Temperature gage	0-200° F minimum	Local purchase
Plug-In-Watt/Voltmeter	Capable of reading 0 to 500 watts	Local purchase
Water inlet hose	MS33514G6 fitting and shutoff valve	Local fabrication
Hot water outlet hose	MS33514G6 fitting and shutoff valve.	Local fabrication
Drain hose	Tee fitting and shutoff valve	Local fabrication
Water drain or container	Approximately 12 – 16 ounces	Local purchase
Power Cord Adapter	892108-G03-PCA	LoopPMA.com

LIST OF
EQUIPMENT
TABLE 2



D. Pressure Test Procedure.

NOTE: Refer to Figure 7 for location of item numbers (10) through (160) tested in this procedure. The pressure test procedure is recommended after assembling Phase 1 water-tight components. The procedure is the same for either the (10) or (-15) tank assembly. If repair(s) have been done to the tank (10) or (-15), you can do a preliminary pressure test without the feed-thru wire assembly (50) and the tank housing (60) in order to perform a better leak inspection. However, some components will need to be removed and reinstalled to complete the Phase 1 water-tight tank assembly.

- (1) Connect Phase 1 water-tight heater assembly to pressure test set-up as shown in Figure 3 and see Figures 4 and 5 for examples and additional information.
- (2) Connect **Inlet** shut-off valve, **Outlet** shut-off valve and **Drain** line shut-off valve with all valves in the closed position.
- (3) Verify the water pressure regulator is between 20-30 psi, Open water Outlet valve first, then open Inlet shut-off valve to allow water to flow through the tank until water starts to flow from the outlet, then close the Outlet valve. Check for water leaks on all fittings and connections.
- (4) Increase water pressure regulator to minimum of 50 psi and maximum of 60 psi for at least 1 minute. Check for water leaks.
- (5) Close **Inlet** shut-off valve, reduce water tank pressure to zero by opening **Outlet** shut-off valve. Then open **Drain** shut-off valve to allow water to drain from the unit. When the water is drained from the W/H, proceed to electrical / operational test procedure or disconnect the water inlet and outlet lines, and remove the water heater from the test bench.

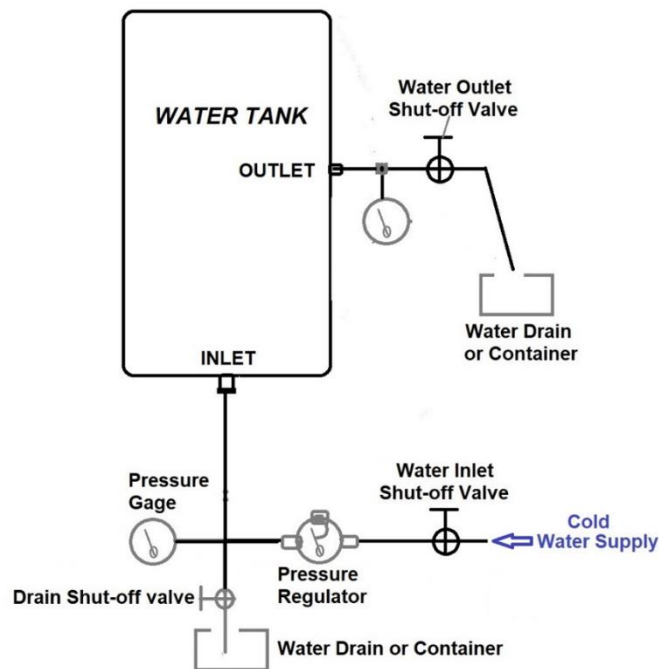

PRESSURE TEST SET-UP
FIGURE 3

PARTIAL TANK ASSEMBLY EXAMPLE
FIGURE 4 (NOT SHOWN)PRESSURE TEST SET-UP EXAMPLE
FIGURE 5



E. Operational/Leak Check Test Procedure.

WARNING: MAKE CERTAIN VOLTAGE IS NOT APPLIED TO TEST SET-UP UNTIL INSTRUCTED AND THAT NO ONE IS TOUCHING ANY PORTION OF THE CONNECTION POINTS OR ELECTRICAL WIRES. FAILURE TO COMPLY WITH THIS WARNING MAY RESULT IN SEVERE ELECTRICAL SHOCK.

NOTE: It is recommended to do the pressure test procedure in the previous section prior to any electrical test procedures. The procedure is the same for either the (10) or (-15) tank assembly. Refer to Figure 7 for location of item numbers used in test procedure.

- (1) Connect water heater to test set-up as shown in Figure 6.
- (2) With the top cover (400) removed, verify that the temperature selector is set at **MED** on the circuit board (270).
- (3) Connect **Inlet** shut-off valve, **Outlet** shut-off valve and **Drain** line shut-off valve with all valves in the closed position. Verify power is showing on Plug-In-Watt/Voltmeter, NO electrical current should be displayed on the meter. RESET the timer to 0:00 (zero) by lightly pushing the reset with a small screwdriver.
- (4) Open main water supply on the test bench and adjust the water pressure regulator to between 20-30 psi. Verify the water heater's power switch is in the Off position and connect the power cord adapter to the water heater being tested, then plug the adapter to the Watt / Voltmeter.
- (5) This procedure along with the next one below will test the water sensor (20) and the total time to heat the full tank, also known as Full Tank Recovery Time. Turn ON the toggle switch (300) and check that the Yellow LED light illuminates on the circuit board (270). Also, note the voltmeter will still show no wattage / current flow. Open **Outlet** shut off valve and slowly Open **Inlet** shut off valve to allow water to flow through the unit. Close **Outlet** shut-off valve once water starts flowing from the outlet tubing. The water sensor is working properly when the Green LED (Heater On light) illuminates on the circuit board (270) and the Watt / Voltmeter shows current flow indicating the heaters are ON.
- (6) Continue to heat the water until the **Green LED** light goes Off, the watts on the meter will drop to almost Zero and the timer will stop counting. Full Tank Recovery Time is acceptable up to 15 minutes. If recovery time exceeds 15 minutes, see Fault Isolation section for probable cause and correction.
- (7) Open Outlet shut-off valve to allow approximately 10 – 16 oz of water to flow into a container and verify **Green LED** light goes ON again, then Close shut-off valve. Check that the water temperature in the container is warm to the touch. Once the Green LED light goes out again, Open Outlet shut-off valve to allow 10 – 16 oz of water to flow into a container and verify the temperature is 100°F ± 10° F. If temperature is not acceptable, see Fault Isolation section for probable cause and correction.



WARNING: EXTRA HOT WATER WILL BE PRODUCED DURING THIS PROCEDURE. TO AVOID BURNS, DO NOT ALLOW HOT WATER FROM THE WATER OUTLET TO COME IN CONTACT WITH CLOTHING OR SKIN.

- (8) This procedure checks the overheat switch thermostat (230) to verify the unit **OPENS** to disconnect electrical power to the circuit and confirms the proper safety function of the device. Use a small straight slot screwdriver to change temperature selector on the circuit board (270) to **OVHT**.

NOTE: When the overheat switch opens, the Plug-In Watt/Voltmeter should indicate 0 (zero) amps. Use caution to open the Outlet shut-off valve to allow 10 oz or more of hot water to flow before checking water temperature.

- (9) Use caution to open the Outlet shut-off valve to allow about 10 oz of hot water to flow before checking water temperature. Temperature of up to 170°F is acceptable. If temperature is not acceptable, replace the overheat switch thermostat (230).
- (10) This procedure checks the Overheat Switch (230) safety device **CLOSES** and returns electrical power back to normal operation. Use a small straight slot screwdriver to change temperature selector on circuit board (270) to **MED**. Use caution to open the **Outlet** shut-off to allow **HOT WATER** out! As soon as the **Green LED** turns on, close **Outlet** shut-off valve. **NOTE:** the Plug-in Watt/Voltmeter should indicate power to circuit is On and eventually the **Green LED** light will go out, indicating the water temperature has reached the MED temperature selected. Allow about 10 oz of water to flow into a container, then check temperature is 110°F \pm 10°F again.
- (11) This final procedure verifies the water sensor (20) functions properly when the tank level goes from **FULL to Less Than Full**. Open Outlet valve and allow a minimum of 16 – 24 ounces of water to flow out. **Green LED** light will be ON. Quickly close water **Inlet** valve, then open **Drain** valve to allow water in tank to drain out.

NOTE: Outlet water line will need to be raised above the height of the Water Heater's Outlet Filling in order for tank to drain. The float switch is functioning properly when the **Green LED** light goes out eventually on circuit board showing water level is too low and the Watt/Voltmeter shows Zero (0) watts. The **Yellow LED** will be illuminated so long as electrical power is available to the circuit board. This is the final test for the water heater to verify its proper operation and safety functions.

- (12) Turn the power off to the test bench. Close **Inlet** shut-off valve, open **Outlet** shut-off valve and then open **Drain** shut-off valve to allow water to drain from the unit. When the water is drained from the W/H, close **Drain** shut-off valve and close **Outlet** shut-off valve.
- (13) Disconnect the Water Heater's electrical connector from test bench. Disconnect the water inlet and outlet lines from the unit, remove the Water Heater from the test bench, drain and dry unit. Verify all sections of form have been filled out. Perform Final Inspection of Water Heater making sure the temperature selector is set at **MED** or as desired by end user.
- (14) Install top cover (400) with external star washer (120) and wing nut (360).

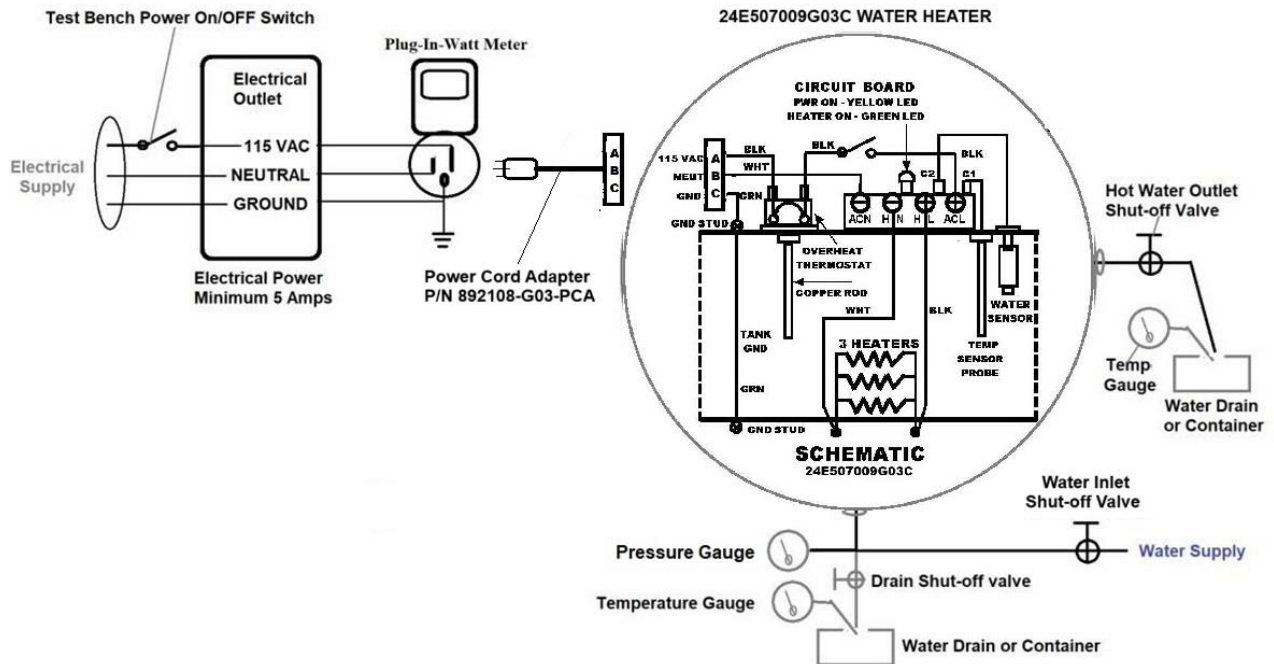

WATER HEATER TEST SET-UP
 FIGURE 6



F. Fault Isolation

Table 3 provides fault isolation procedures for the Water Heater. The left column lists the TROUBLE, the center column provides the PROBABLE CAUSE, and the right column provides the CORRECTION.

NOTE: Refer to Figure 7 for location of item numbers used in fault isolation.

TROUBLE	PROBABLE CAUSE	CORRECTION
No hot water	No electrical power	Check applicable circuit breaker, connector (330) and loose connection on circuit board (270)
	Defective water sensor or connection to circuit board	Install jumper wire at circuit board W/S or replace water sensor (20)
	Defective heater element(s)	Replace heater elements (170)
	Defective temperature probe	Replace temperature probe (30)
	Defective overheat switch	Replace overheat switch (230)
	Defective toggle switch	Replace toggle switch (300)
	Defective circuit board	Replace circuit board (270)
Water does not heat to desired temperature	Temperature selector not on correct temperature setting	Adjust temperature selector on circuit board (270)
	Defective temperature probe	Replace temperature probe (30)
	Defective circuit board	Replace circuit board (270)
	Low voltage from power source	Check voltage and adjust
Water overheats	Temperature selector not on correct setting	Adjust temperature selector on circuit board (270)
	Defective temperature probe	Replace temperature probe (30)
	Defective overheat switch	Replace overheat switch (230)
	Defective circuit board	Replace circuit board (270)

FAULT
ISOLATION
TABLE 3



G. Temperature Adjustment

WARNING: TO AVOID DAMAGE TO CIRCUIT BOARD OR ELECTRICAL SHOCK, DO NOT ADJUST TEMPERATURE WITH POWER ON THE WATER HEATER.

NOTE: Refer to Figure 7 for location of item numbers used in thermostat adjustment.

- (1) Remove wing nut (360), washer (120) and top cover (400).
- (2) Use a straight slot screwdriver to rotate temperature selector switch on circuit board (270) clockwise to increase temperature or counter-clockwise to decrease temperature.
- (3) Install top cover (400) and attaching hardware.

3. AUTOMATIC TEST REQUIREMENTS

(NOT APPLICABLE)

4. DISASSEMBLY

H. General

Complete disassembly of the water heater is neither desired nor recommended. Disassemble the water heater only to the point necessary to perform a repair. See Testing and Fault Isolation, and Inspection/Check to determine the extent of disassembly required.

I. Disassembly Procedure

NOTE: Refer to Figure 7 for location of item numbers used in disassembly procedure.

- (1) Remove wing nut (360), washer (120) and top cover (400). The schematic label (-405) is adhered to the top cover and can be replaced as necessary. Refer to Figure 2 for sample picture of the schematic label.
- (2) To remove temperature probe assembly (30), remove quick connect from circuit board (270) and use a wrench to unscrew probe and o-ring (90).
- (3) To remove overheat switch thermostat (230), remove quick connect wire terminals from the top of the overheat switch and use a wrench to unscrew overheat switch.
- (4) Do not remove toggle switch (300) or switch plate (310) unless replacement is required.
- (5) Do not remove strain relief (340), grommet (-337) or connector (330) from power wire assembly (320) unless replacement is required.
- (6) To remove circuit board (270), remove temperature probe quick connect and use a small straight slot screwdriver to unscrew all the terminals and remove all the wires. Remove hex standoff (260), washer (120), white neutral wire (200) and wire lug from power wire assembly (320). Remove nut (280) and washer (120) then pull circuit board up from hex standoff mounts.

- (16) *[Illegible text]*
- (17) *[Illegible text]*

5. CLEANING

J. Cleaning Materials

Table 4 specifies cleaning materials. Equivalent substitutes may be used.

ITEM	SOURCE
Cloth, lint-free	Local purchase
Mild Detergent	Local purchase
Mild Cleaning Solvent	Local purchase

CLEANING
MATERIALS TABLE 4

K. Cleaning Procedure

- (1) Clean interior and exterior of main housing, top, bottom covers and modified tank with mild detergent solution. Rinse thoroughly with clear running water and dry with clean cloth.
- (2) Clean water fittings with mild cleaning solvent. Rinse thoroughly with clear running water and dry with clean cloth.
- (3) Wipe dust and dirt from electrical connections with lint-free cloth.



6. INSPECTION/CHECK

A. General

A preliminary cleaning before initial inspection will facilitate location of obvious defects.

L. Inspection Procedure

- (1) 1. Wash the component with a mild detergent solution. 2. Rinse thoroughly with clean water. 3. Dry the component with compressed air. 4. Inspect the component for any visible defects. 5. If any defects are found, repair or replace the component as necessary.
- (2) 1. Inspect the component for any visible defects. 2. If any defects are found, repair or replace the component as necessary.
- (3) 1. Inspect the component for any visible defects. 2. If any defects are found, repair or replace the component as necessary.
- (4) 1. Inspect the component for any visible defects. 2. If any defects are found, repair or replace the component as necessary.
- (5) 1. Inspect the component for any visible defects. 2. If any defects are found, repair or replace the component as necessary.

7. REPAIR

M. General

Repair of the water heater is limited to replacement of defective parts using standard shop practices. Replace all parts which fail Inspection/Check criteria. Minor thread damage may be repaired. Minor scratches and minor surface damage may be repaired.

N. Repair materials are listed in Table 5. Equivalent substitutes may be used for items listed.

ITEM	SOURCE
Film treatment for anodized surfaces	Local purchase
Teflon tape	Local purchase
Loctite	Local purchase
RTV 732 Sealant	Local purchase



REPAIR
MATERIALS
TABLE 5



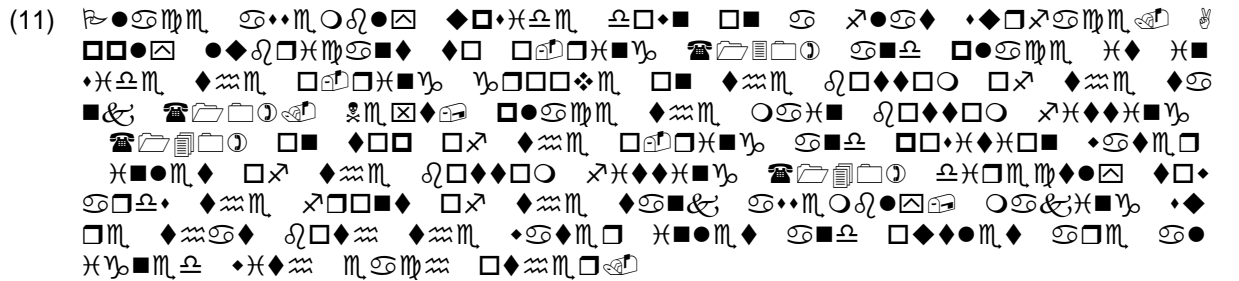

ABBREVIATED COMPONENT MAINTENANCE MANUAL
MODEL NUMBER: 24E507009G03C

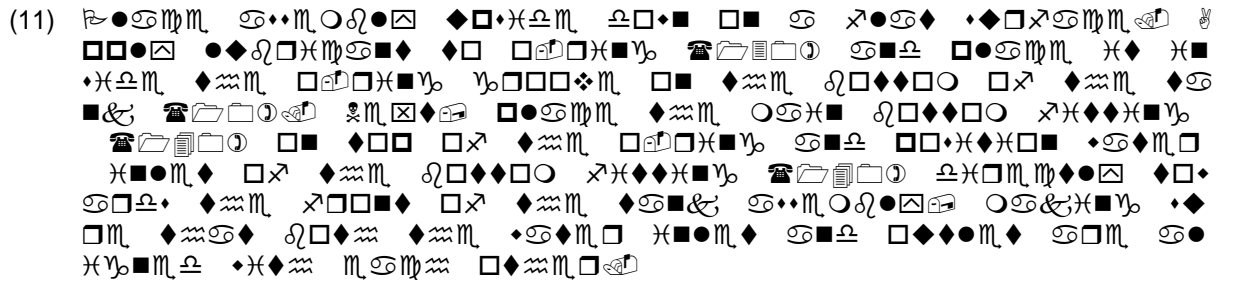
- (3) ...
- (4) ...
- (5) ...
- (6) ...
- (7) ...
- (8) ...
- (9) ...
- (10) ...

- (11) 

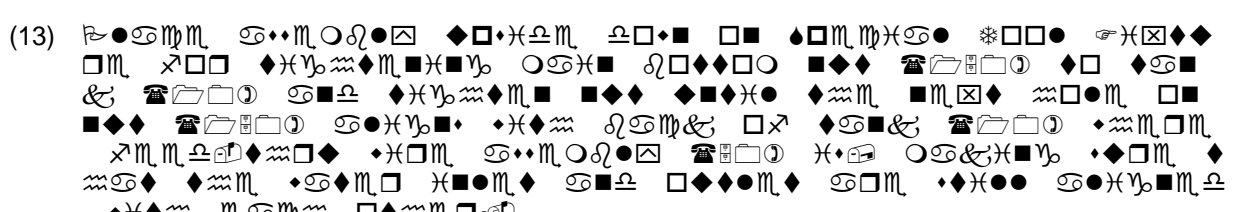
(11) 
- (12) 

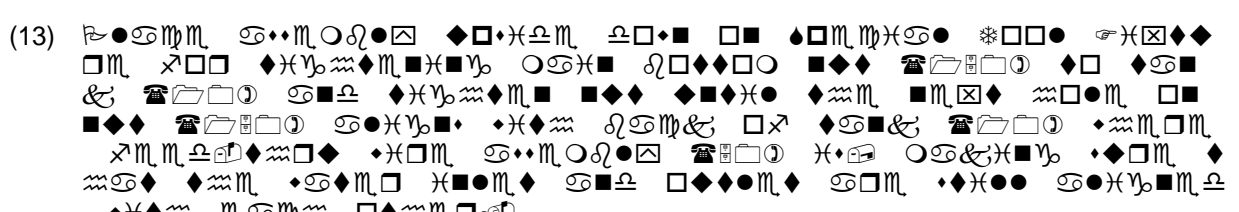
(12) 
- (13) 

(13) 
- (14) 

(14) 
- (15) Once the assembly above has passed the PTP, continue with the next assembly procedure – **Phase 2 (Operational / Leak Check Assembly)**
- (16) Install heater elements (170) by sliding them into the sleeves of the main bottom fitting (140), making sure that the bracket of the heater element aligns with the threaded stud of the bottom fitting. Install washers (390) and nuts (180) and tighten nuts securely for each heater element.
- (17) Install feed-thru wires (50) by sliding them in through the hole of the main bottom nut (150) and install terminal ring (220) on the green ground wire. Then place the terminal ring (220) of the green wire on the stud of the main bottom fitting (140) and secure with washer (120) and bottom fitting hex standoff (410). Use a close end splice (210) to connect the white (neutral) wire to the three heating element's white labeled wires. Use another close end splice (210) to connect the black (load) wire to the other three heating element's wires. Tuck all wires below the surface of the hex standoff (410). Refer to water heater bottom view on Figure 7.
- (18) With the water heater right-side up, install the overheat switch thermostat (230) and hand tighten about 10 in-lbs with wrench but Do Not Over Torque!
- (19) Install top electrical plate (240) and slide the wires from the water sensor (20) and temperature probe assembly (30) through the holes of the top plate (240) and aligning with the overheat switch thermostat (230). Secure the top plate (240) with washer (290) and nut (250). Install washer (120) and electrical plate hex standoff (260) on the threaded stud of the top of tank (10). Install green ground wire (190) to top plate (240) with washer (120) and electrical plate hex standoff (260). Refer to water heater top view on Figure 7.



- (20) Install circuit board (270) by connecting the wires from the water sensor (20) first, then placing the circuit board (270) on the hex standoffs (260) of the top plate (240), making sure the black and white wires of the feed-thru assembly (50) are then connected to circuit board (270). Install washer (120) and nut (280) on top of circuit board and tighten. Connect the temperature probe wires (30) to circuit board's quick connector labeled T/S. Install white neutral wire (200) with terminal ring on circuit board's threaded stud of the hex standoffs (260) and the other end of white wire (200) connected to the circuit board terminal. NOTE: The circuit board will be securely mounted on the next procedure. Refer to top view Fig. 7 and circuit board connections Fig. 2.
- (21) Install power wire assembly (320) by sliding the wires through the hole on the back of the tank housing (60) and securing with strain relief (340), making sure wires can be connected to overheat switch thermostat (230), the grounding point on back of the tank housing (60) with screw (110), washer (120) and nut (280) along with the other terminal ring of the green ground wire (190). Connect the white (neutral) wire to the circuit board's threaded stud on the hex standoff (260) with terminal ring (220), and secure the wire and circuit board with washer (120) and another hex standoff (260). Refer to top view Fig. 7 and circuit board connections Fig. 2.
- (22) Install On/Off toggle switch (300) by inserting the toggle switch through the hole on the front of the tank housing (60) and securing with On/Off toggle plate (310) which includes internal star washer and nut. Tighten nut making sure locking ring is properly engaged with the slot on the front hole of housing. Connect blade connector to overheat switch (230) and other wire to circuit board (270) terminal connection. Refer to top view Fig. 7 and circuit board connections Fig. 2.
- (23) Inspect the above items are properly assembled before proceeding with Operational/Leak Check Test (OLCT).
- (24) Once the assembly has passed the test above, continue with the next assembly procedure – **Phase 3 (Final Tank Assembly)**
- (25) Make sure that the temperature selector on the circuit board (270) is set to MED or as desired, and do a final inspection of the components on the top of water heater.
- (26) Install clear locking plug (380) into hole on top of the tank housing (60).
- (27) Install top cover assembly (400) and secure with washer (120) and wing nut (360).
- (28) Install countersunk screw (350) and wing nut (360) through the base of the water heater, making sure that the wing nut (360) is positioned correctly between the bottom fitting hex standoff (410). Refer to Fig. 7 water heater bottom view.
- (29) Install bottom cover (370) by aligning holes on the cover with the main bottom fitting (140), making sure that the top edge of the bottom cover (370) gets tucked into the top half-bottom cover (40) which is mounted on the tank housing (60). Secure bottom cover (370) with screws (110) and washers (120). Refer to Fig. 7 water heater bottom view.
- (30) Place protective covers on the inlet fitting (part of 140), the outlet fitting (80) and the electrical connector assembly (330).



9. SPECIAL TOOLS, FIXTURES, AND EQUIPMENT

Q. General

Table 7 lists the special tools, fixtures, equipment, and consumables required to maintain the water heater. Standard shop tools, fixtures, and equipment are not listed. Equivalent substitutes may be used for listed items.

ITEM	SOURCE
Operational test set-up	Local fabrication per Figure 6
Water Source, 20-30 psi \pm 2 psi	Local fabrication
Power Supply, 115VAC, 400 or 60 Hz, 210 Watts, Min 5 amps, single phase	Local purchase
Temperature gage, 0-200° F	Local purchase
Multimeter, Capable of reading 0 to 10 Amps	Local purchase
Water inlet hose with MS33514G6 fitting and shutoff valve.	Local fabrication
Hot water outlet hose with MS33514G6 fitting and shutoff valve.	Local fabrication
Drain hose with shut- off valve	Local fabrication
Water container, One gallon minimum	Local purchase
Chemical film treatment for anodized surfaces	Local purchase
Teflon tape	Local purchase
Loctite 263 (as required)	Local purchase
RTV 732 Sealant	Local purchase
Cloth, lint-free	Local purchase
Mild Detergent	Local purchase
Mild Cleaning Solvent	Local purchase

SPECIAL TOOLS, FIXTURES, EQUIPMENT,
AND CONSUMABLES TABLE 7



(f) Units Per Assy

The number appearing in this column are the total quantity of the listed part required in its immediate assembly or location.

(3) Manufacturer's Code

A five-letter code preceded by the letter V is used to identify the true manufacturer of detail parts which are not assigned a part number by the prime manufacturer. This code is known as the manufacturer's code. The manufacturer's code is located in the nomenclature column of the Illustrated Parts List. The manufacturer's code number identifies the original manufacturer, and is in accordance with the Commercial And Government Entity (CAGE) program code for Manufacturer. Table 8 shows the manufacturer codes used in the Illustrated Parts List.

MFG or CAGE Code	Name and Address
69M83	Loop Aerospace 21618 Golden Triangle Road #101 Santa Clarita, CA 91350
05972	Loctite Co. (Henkel Corporation) 26235 First Street Westlake Ohio 44145
57XH2	Arrow, Marco Poloweg 11 5928 NL Venlo, NL
0A050	Hi-Line, 2121 Valley View Lane, Dallas, TX 75232
0XUH0	Selco, 8780 Technology Way, Reno, NV 89521
3A054	McMaster Carr, 9630 Norwalk Blvd, Santa Fe Springs, CA 90670
0FPA0	Monroe Aerospace 399 East Drive, Melbourne, FL 32904
80205	National Aerospace Standards
81352	Air Force-Navy Aeronautical Specifications
96906	Military Standards

MANUFACTURER
 CODES TABLE 8

R. Detailed Parts List

The Detailed Parts List consists of illustrations and columnar parts breakdowns of the water heater assembly, subassemblies, and detail parts that may be disassembled, repaired or replaced, and reassembled. Each part or subassembly is indented to show relationship back to the next higher assembly. See Figure 7.



Exploded View Not Available

Water Heater Assembly
Figure 7 (Sheet 1 of 4)

Water Heater Top View

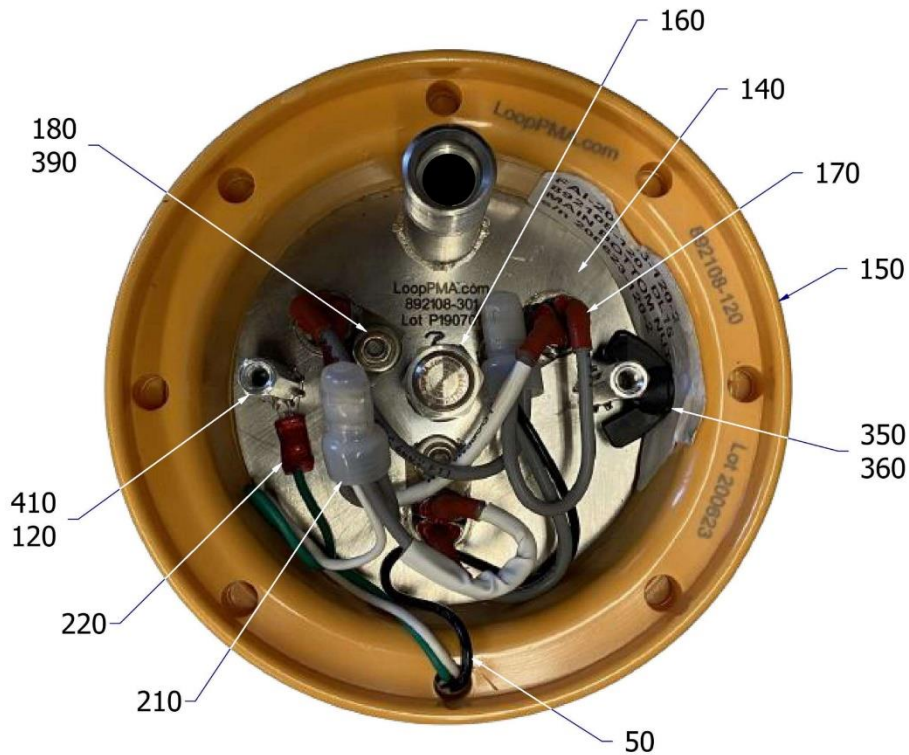
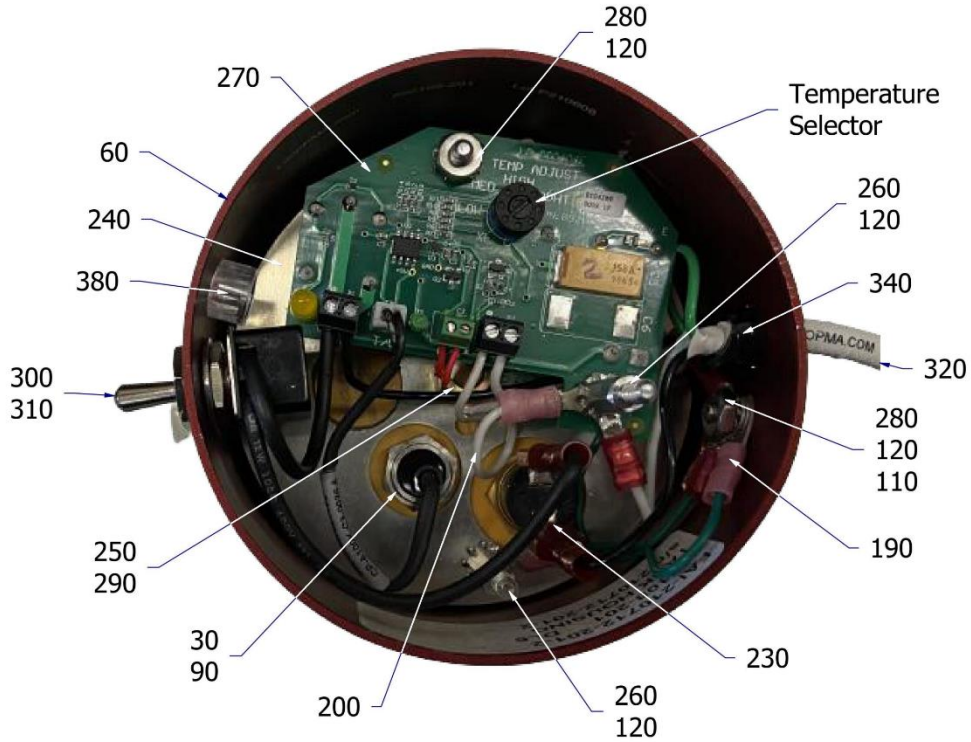

Water Heater Bottom View
 Figure 7 (Sheet 2 of 4)



ABBREVIATED COMPONENT MAINTENANCE MANUAL
MODEL NUMBER: 24E507009G03C

FIG. ITEM	PART NUMBER	AIRLINE STOCK NO.	NOMENCLATURE	EFFECT.	UNITS PER ASSY
PHASE 2 – OPERATIONAL/LEAK CHECK TANK ASSEMBLY					
7 170	892108-06282		HEATER ELEMENT (70-watt)		3
180	MS21043-08		NUT, SELF LOCKING		3
190	892108-181-3G		GREEN GROUND WIRE		1
200	892108-181-3W		WHITE NEUTRAL WIRE		1
210	35653		SPLICE, CLOSE END		2
220	MS25036-149		RING TERMINAL		4
230	892108-OA-130		THERMOSTAT, OVERHEAT SWITCH		1
240	892108-205A		TOP ELECTRICAL PLATE ASSY		1
250	MS35649-2252		NUT, 1/4-20	A	1
-255	MS35649-252		NUT, 10-32 ACORN	C	1
260	892108-232		STANDOFF, ELECTRICAL PLATE HEX		3
270	892108-703		CIRCUIT BOARD		1
280	MS35649-284		NUT, 8-32 STAINLESS STEEL		2
290	MS35335-61		WASHER, 1/4" EXTERNAL STAR		1
300	892108-766		SWITCH, ON / OFF TOGGLE		1
310	892108-766P		PLATE, ON / OFF SWITCH		1
320	892108-183-20		POWER WIRE ASSY		1
-325	892108-820		HEAT SHRINK, POWER WIRE ASSY		1
330	MS3476A10-6P		CONNECTOR ASSY		1
-335	BACC45FT14C7P		ALT P/N CONNECTOR ASSY		1
-337	892108-814		GROMMET, BACKSHELL CONNECTOR		1
340	892108-631		STRAIN RELIEF		1
PHASE 3 - FINAL ASSEMBLY					
7 350	MS24693C-53D		SCREW, COUNTERSUNK, STAINLESS		1
360	892108-621		NUT, WING		1
370	892108-415		BOTTOM COVER		1
380	892108-611		CLEAR LOCKING PLUG		1
390	MS15795-807		WASHER, FLAT		2
400	892108-423A		TOP COVER ASSEMBLY		1
-405	892108-813		LABEL, SCHEMATIC		A/R
410	892108-238		STANDOFF, BOTTOM FITTING HEX		2
-415	892108-703-CS		FITTING, TEST PORT	C	A/R
-417	892108-518-NPT		PLUG, TEST PORT PIN	C	A/R

Figure 7 (Sheet 4 of 4)